



A world of solutions to improve things moving

**Horizontal
Bearing
Assemblies
HSR Range**



- Technical and Design Support
- Quality Plans and Standards
- Research, Development and Test Facilities
- Materials for all Duties
- Sales and Support Worldwide
- Licensee to Waukesha Bearings
- Special Studies and Analysis Available
- Rotor Dynamics Analysis
- Specialised Bearing Manufacture
- Repairs to White Metal Bearings
- Audited and Listed to SABS ISO 9001:2000 standards

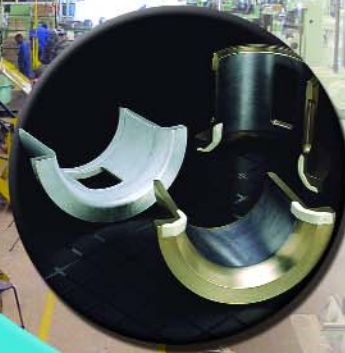
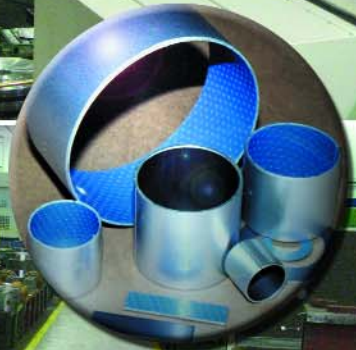

GB Bearings (Pty) Ltd operates from a network of facilities situated in Durban, Johannesburg and Cape Town.

GB Bearings has always been in the forefront of technological advancement in the design and manufacture of plain bearings and bearing materials for a wide variety of industrial applications. Our facilities are equipped to manufacture and repair bearings ranging in size up to bore diameters of 5500mm.

A world of solutions to improve things moving

Introduction	2	Special Designs	13
<hr/>		<hr/>	
General Description	2	Optional Features	14
<hr/>		Water cooling	
Size Tables	3	External pressure lubrication	
Base mounted		Hydrostatic jacking	
End flange mounted		Profile bore journal bearings	
Centre flange mounted		Tilting pad journal bearings	
<hr/>		Instrumentation:	
Seals	6	Temperature sensors	
<hr/>		Proximity probes	
Machine Seals	7	Insulation	
<hr/>		Materials	
<hr/>		<hr/>	
Shaft Dimensions	8	Rotor Dynamics	15
Locating shafts		<hr/>	
Non-locating shafts		Exchange Service	15
<hr/>		<hr/>	
Bearing Selection	10	Reference Codes	16
Load capacity		<hr/>	
Speeds and clearances		Ordering Details	17
Shaft diameter		<hr/>	
Limits of natural cooling			
Thrust load			
Confirmation of selection			

*GB Bearings warrants that products described in this handbook are free from defects in workmanship and material but, unless expressly agreed in writing.

GB Bearings gives no warranty that these products are suitable for any particular purpose or for other use under any specific conditions notwithstanding that such purpose would appear to be covered by this publication. GB Bearings accepts no liability for any loss, damage or expense whatsoever arising directly or indirectly from the use of their products. All business undertaken by GB Bearings is subject to their standard Conditions of Sale, copies of which are available on request. GB Bearings products are subject to continual development and GB Bearings reserves the right to make changes in the specification and design of their products without prior notice.

*Throughout this handbook, the term "GB Bearings" refers to GB Bearings (Pty) Ltd.

Date of Publication: May 2009

Introduction

GB Bearings HSR bearing assemblies are a range of plain bearings, for shaft sizes from 60mm to 380mm, ready for fitting to electric motors, fans, blowers, pumps, and any other machinery where free standing or flange mounted bearings are required.

They incorporate the latest in GB Bearings' wide experience in designing bearings for rotating plant as well as plain and tilting pad bearings for which they are well known throughout the world.

General Description

The standard GB Bearings HSR assembly contains a horizontal, plain journal bearing of split construction, with plain thrust faces for shaft location. The bearing is air cooled, lubricated with an oil pick-up ring dipping into a built in oil sump. The HSR casing is fitted with floating labyrinth seals at each end.

The assembly may be base mounted, or supported on an end flange or centre flange.



HSR Base Mount with top cover removed showing optional tilting thrust pad arrangement

The following features may be incorporated into a customer's design to meet their particular requirements:

Water cooling

Where safe limits for air cooling are exceeded.

External pressure lubrication

For higher speeds and loads.

Hydrostatic jacking

For heavy loads at start-up.

Tilting pad journals

For low vibration levels in higher speed machinery. Lemon bore and four lobe profiles are also available to deal with such requirements.

Axial thrust features

For most installations plain or taper land thrust faces for adequate. For higher thrust levels, or where a greater safety margin is required, GB Bearings standard tilting thrust pads can be incorporated.

Instrumentation

e.g. temperature recording instruments with alarm contacts as a further option.

Insulation

Insulation is provided by P.T.F.E. bonded to the bearing housing.

Shaft Size

Shaft sizes less than 60mm and greater than 380mm may be accommodated by special order.



Additional sealing

Standard assemblies are supplied with SS type seals to IP44 protection (see page 6). Alternative sealing arrangements to IP55 and IP56 are available. Additional machine seal for the end flange mounted HSR can be supplied.

The standard materials used in the various components are:

Casing

Grey iron to BS1452-1977.
Grade 220 (Equivalent: DIN 1691-1967 GG20/25).

Bearing

Steel to BS4360 Grade 43A or S.G.
iron grade 420/12 to BS 2789-1985.

Bearing lining

GB Bearings GMA 106 whitemetal.

Labyrinth Seals

Thermoplastic material/phenolic resin

Insulation

P.T.F.E.

When ordering, standard assemblies are identified by a combined bearing and seal code (see page 16). Options such as instrumentation are not coded and should be specified as an addition.

Size Tables: Table 1 - Dimensions of base mounted unit

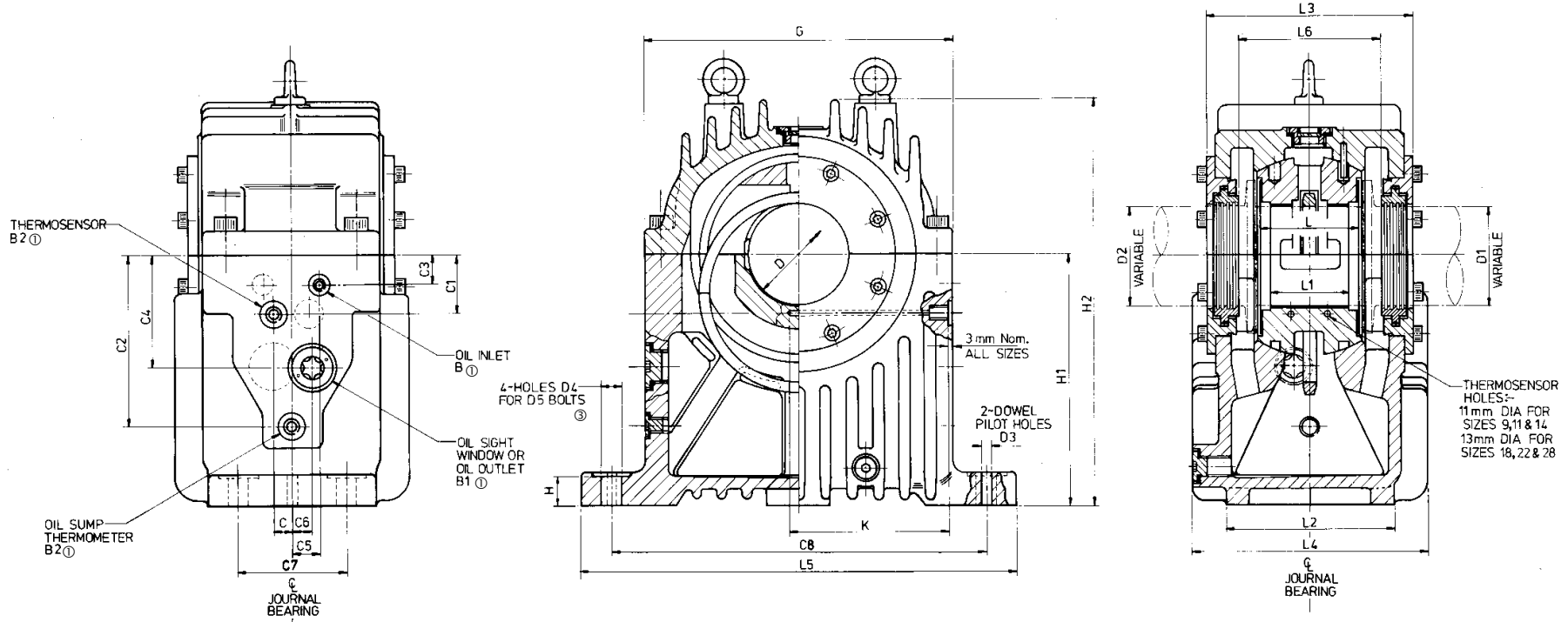

Frame size	For shafts Dia.D	D1 variable	D2 variable	D3	D4 <	D5	B <=	B1 <=	B2 <=	C	C1	C2	C3	C4	C5	C6	C7	C8	G	H	H1	H2	K ±3	L	L1	L2	L3	L4	L5	L6	Oil capacity (litres)	Approx weight Kg
9	80	80	80	10.4	22	M16	Rp ^{3/8}	Rp1 ^{1/4}	Rp ^{1/2}	20	55	137	28	95	35	23	90	300	265	35	190	318	112	80	64	145	186	186	355	118	1.6	55
		90	90																													
		100	100																													
		110	110																													
11	100	100	100	10.4	26	M20	Rp ^{3/8}	Rp1 ^{1/4}	Rp ^{1/2}	23	65	150	38	100	40	23	100	375	315	48	225	368	134	100	80	165	216	216	450	148	3.5	80
		110	110																													
		125	125																													
		140	140																													
14	140 (160)	125	125	10.4	30	M24	Rp ^{3/8}	Rp1 ^{1/2}	Rp ^{1/2}	29	90	180	50	130	50	29	125	450	370	60	265	450	164	125	105	205	256	256	540	188	4.8	140
		140	140																													
		160	160																													
		180	180																													
18	180 (200)	160	160	15.5	40	M30	Rp ^{1/2}	Rp1 ^{1/2}	Rp ^{1/2}	34	112	215	75	155	65	34	150	560	440	70	315	555	199	160	135	245	296	300	660	228	8.2	240
		180	180																													
		200	200																													
		225	225																													
22	225 (250)	200	200	15.5	46	M36	Rp ^{3/4}	Rp2	Rp ^{1/2}	40	137	245	88	180	80	40	200	670	560	80	375	670	260	200	170	310	380	380	800	306	15.6	420
		225	225																													
		250	250																													
		280	280																													
28	280 (300)	250	250	20.6	55	M42	Rp ^{3/4}	Rp2 ^{1/2}	Rp ^{1/2}	50	155	310	95	220	106	50	250	800	690	90	450	820	324 290	250	215	370	442	450	950	350	25.5	780
		280	280																													
		315	315																													
		355	355																													

Notes: ① Tapped features also in opposite side of unit identically positioned to refs C to C6 inclusive relative to journal bearing centre lines.

Notes: ② Rp = B S P

③ Standard coarse clearance holes for bolts D5.

Notes: ④ All dimensions in mm with the exception of B, B1 & B2.

⑤ Dimensions in brackets thus (160) are on units to special order.

Size Tables: Table 2 - Dimensions of end flange mounted unit

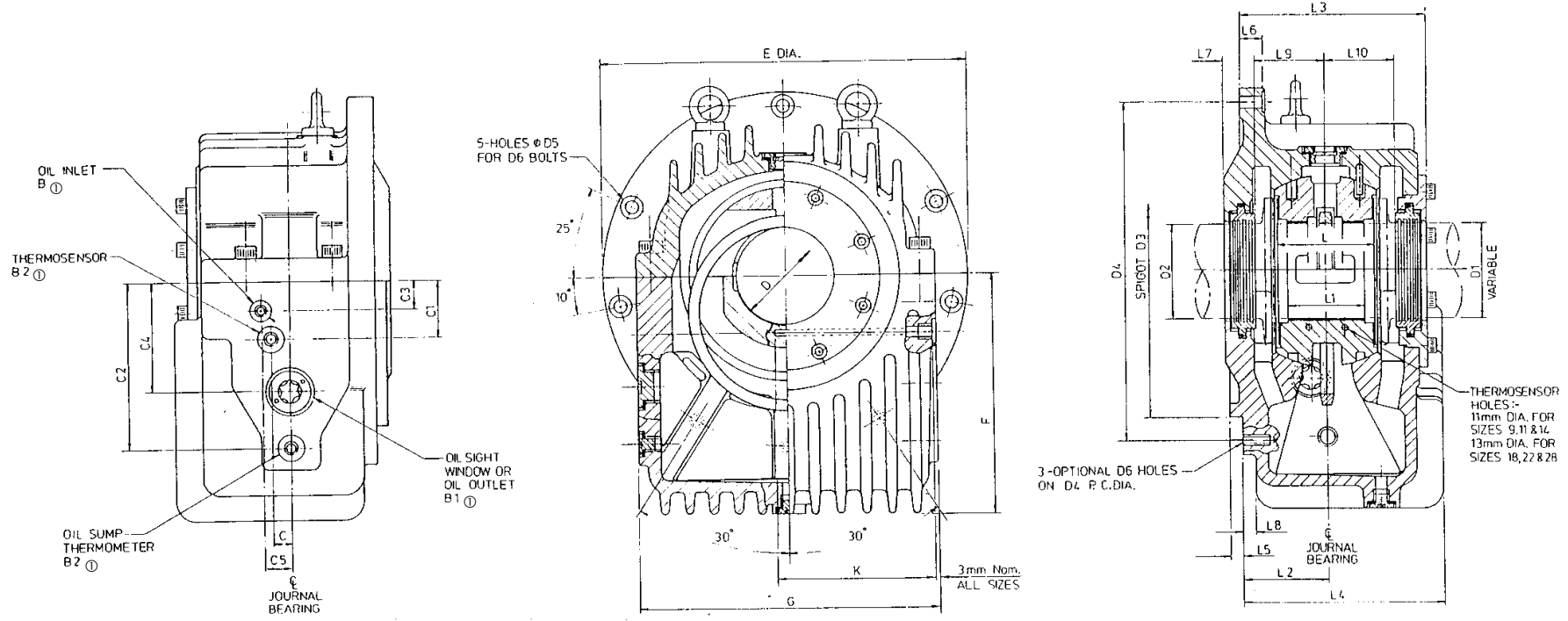

Frame size	For shafts Dia. D	D1 variable	D2	D3	D4	D5	D6	B ≤	B1 ≤	B2 ≤	C	C1	C2	C3	C4	C5	E	F	G	K ±3	L	L1	L2	L3	L4	L5	L6	L7	L8	L9	L10	Oil capacity (litres)	Approx. weight Kg
9	80	80	100	280	310	14	M12	Rp ³ / ₈	Rp1 ¹ / ₄	Rp ¹ / ₂	20	55	175	28	95	35	340	240	265	112	80	64	70	163	163	10	13	21	10	59	59	2.5	60
		90																															
		100																															
		110																															
11	100	100	125	315	350	14	M12	Rp ³ / ₈	Rp1 ¹ / ₄	Rp ¹ / ₂	23	65	195	38	105	40	380	270	310	134	100	80	80	188	188	12	17	26	12	74	74	4.0	90
		110																															
		125																															
		140																															
14	125	125	160	355	415	18	M16	Rp ³ / ₈	Rp1 ¹ / ₂	Rp ¹ / ₂	29	90	240	50	130	50	460	330	365	162	125	105	100	228	235	14	23	23	12	90	94	7.3	140
		140																															
		160																															
		(160)																															
18	180	160	200	400	490	22	M20	Rp ¹ / ₂	Rp1 ¹ / ₂	Rp ¹ / ₂	34	112	260	75	155	65	540	380	440	199	160	135	116	264	266	17	25	29	15	110	114	11.7	220
		180																															
		200																															
		(200)																															
22	200	200	250	500	620	26	M24	Rp ³ / ₄	Rp2	Rp ¹ / ₂	40	137	340	88	180	80	680	430	550	260	200	170	150	340	340	22	37	33	15	142	153	21	430
		225																															
		(250)																															
		250																															
28	250	250	315	600	770	33	M30	Rp ³ / ₄	Rp2 ¹ / ₂	Rp ¹ / ₂	50	155	390	95	220	106	850	485	690	324	250	215	170	385	395	26	42	41	15	175	184	30.5	790
		280																															
		315																															
		(355)																															

Notes: ① Tapped features also in opposite side of unit identically positioned to refs. C to C6 inclusive relative to journal bearing centre lines.

Notes: ② Rp = B S P

③ Dimensions in brackets thus (160) are on units to special order.

Notes: ④ All dimensions in mm with the exception of B, B1 & B2.

Size Tables: Table 3 - Dimensions of centre flange mounted unit

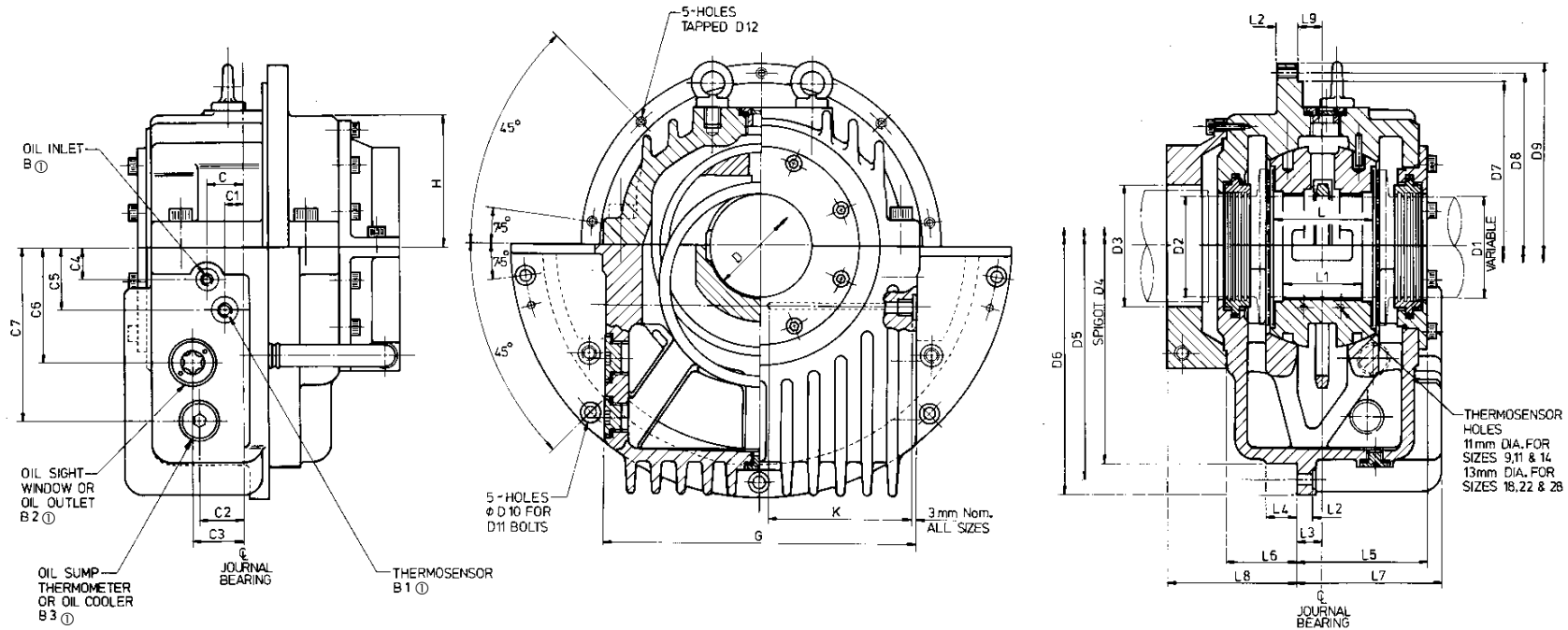

Frame size	For shafts Dia. D	D1 variable	D2	D3	D4	D5	D6	D7	D8	D9	D10	D11	D12	B <=	B1 <=	B2 <=	B3 <=	C	C1	C2	C3	C4	C5	C6	C7	G	H	K ±3	L	L1	L2	L3	L4	L5	L6	L7	L8	L9	Oil capacity (litres)	Approx. weight Kg
9	80	80	100	121.5	375	400	426	270	285	300	11	M10	M6	Rp ³ / ₈	Rp ¹ / ₂	Rp ¹ / ₄	Rp ¹ / ₄	35	20	50	50	28	55	95	150	255	105	110	80	64	17	20	30	122	60	122	125	20	2.2	55
	90	90																																						
	100	100																																						
	110	110																																						
11	100	100	125	151.5	450	475	500	320	340	356	14	M12	M6	Rp ³ / ₈	Rp ¹ / ₂	Rp ¹ / ₄	Rp ¹ / ₄	40	23	55	65	38	65	100	165	300	130	130	100	80	17	20	30	137	75	140	140	20	3.9	85
	110	110																																						
	125	125																																						
	140	140																																						
14	125	125	160	191.5	530	560	600	380	400	426	18	M16	M6	Rp ³ / ₈	Rp ¹ / ₂	Rp ²	Rp ¹ / ₄	50	29	70	75	50	90	130	200	356	160	162	125	105	22	25	30	158	87	165	160	25	5.8	140
	140	140																																						
	160	160																																						
	180	180																																						
18	160	160	200	241.5	630	670	710	450	475	500	22	M20	M8	Rp ¹ / ₂	Rp ¹ / ₂	Rp ²	Rp ¹ / ₄	65	34	80	80	75	112	155	240	420	190	195	160	135	22	25	30	180	107	190	185	25	8.6	230
	180	180																																						
	200	200																																						
	225	225																																						
22	200	200	250	291.5	800	850	900	570	600	630	26	M24	M10	Rp ³ / ₄	Rp ¹ / ₂	Rp ²	Rp ¹ / ₄	80	40	100	100	88	137	180	310	530	235	260	200	170	27	30	30	230	138	230	215	30	22.4	425
	225	225																																						
	250	250																																						
	280	280																																						
28	250	250	315	356.5	1000	1060	1120	730	765	800	33	M30	M12	Rp ³ / ₄	Rp ¹ / ₂	Rp ² / ₂	Rp ¹ / ₄	106	50	130	130	95	155	220	385	675	300	324 290	250	215	27	30	35	265	182	285	270	30	40.8	860
	280	280																																						
	315	315																																						
	355	355																																						

Notes: ① Tapped features also in opposite side of unit directly in line to refs C to C7 inclusive.

Notes: ② Rp = B S P

③ Dimensions in brackets thus (160) are on units to special order.

Notes: ④ All dimensions in mm with the exception of B, B1, B2 & B3.

Seals: Table 4 - Dimensions of standard seals

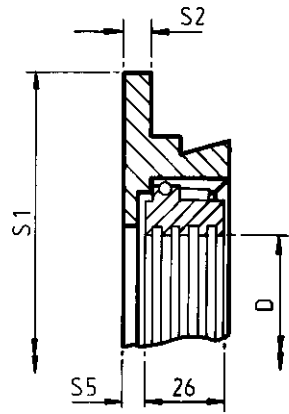

FLOATING LABYRINTH SEAL
-TYPE **SS**
PROTECTION TO IP44

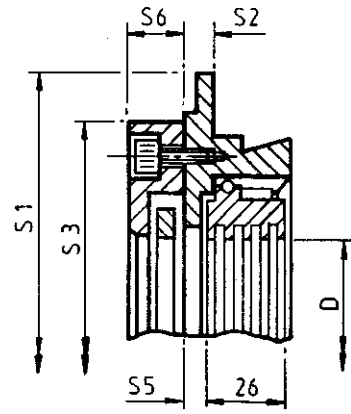

FLOATING LABYRINTH SEAL
WITH BAFFLE -TYPE **SZ**
PROTECTION TO IP56

$\times 5$

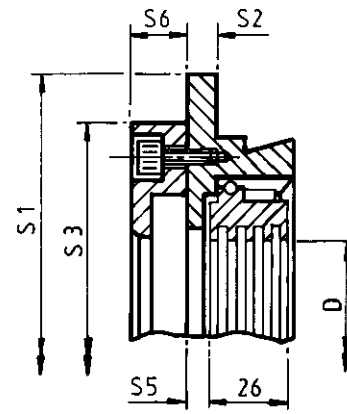

FLOATING LABYRINTH SEAL
WITH BAFFLE -TYPE **SB**
PROTECTION TO IP55

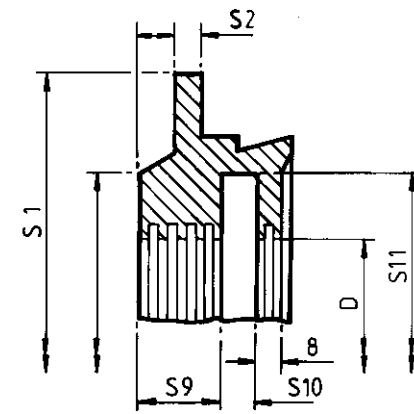

RIGID LABYRINTH SEAL
[DUAL SYSTEM] -TYPE **SD**
PROTECTION TO IP 44

Frame size	Nominal bore - D	S1	S2	S3	S5	S6	S9	S10	S11
9	80	195	12	162	8	30	27	14	140
	90								
	100								
11	100	226	12	194	8	30	27	16	170
	110								
	125								
14	125	270	12	234	8	30	27	18	212
	140								
	160								
18	160	320	16	281	8	30	27	21	260
	180								
	200								
22	200	388	22	338	11	30	27	24	316
	225								
	250								
28	250	465	22	413	11	30	27	27	390
	280								
	315								
	355								

Notes: Protections to IP44, IP55 & IP56 in accordance with BS 4999: Part 20 1972

All dimensions in mm

Table 5: Due to the low absolute air pressures which occur in the vicinity of the shaft ends on electrical motors, it is recommended that a vented baffle zone is provided adjacent to the inner seals to ensure that oil vapour is not extracted into the motor casing. A standard range of machine seals for each frame size of HSR (end mounted) bearing is offered as an accessory.

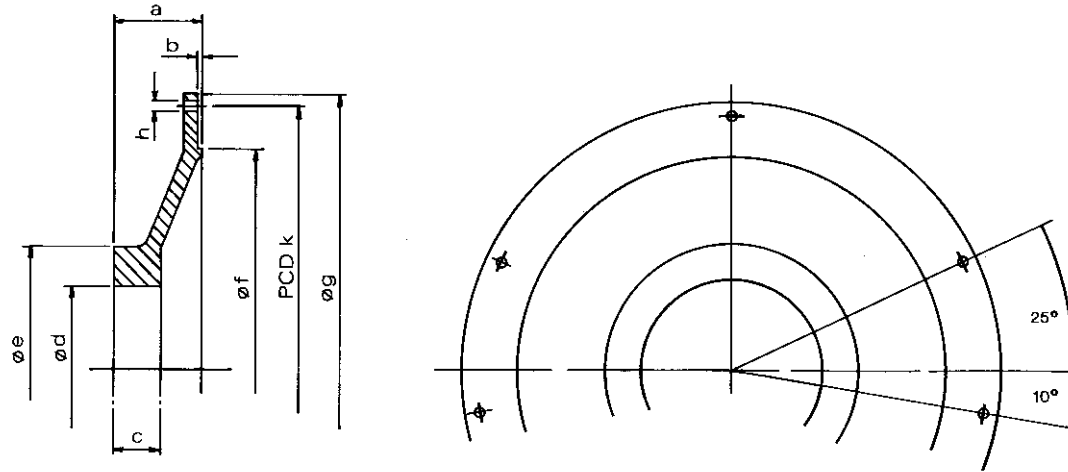

Frame size	a	b	c	Ød*			Øe	Øf	Øg	h	P.C.D.k
				Min.	Max.	Std.					
9	60	3	35	110	130	121.5	160	280	380	6.6 for 6 X M6	360
11	65	3	35	145	160	151.5	180	315	420	6.6 for 6 X M6	400
14	70	3	35	190	207	191.5	230	355	395	6,6 for 6 X M6	375
18	75	3	40	210	257	241.5	290	400	460	9 for 6 X M8	430
22	80	3	40	290	322	291.5	360	500	570	9 for 6 X M8	535
28	85	3	50	355	382	356.5	440	600	680	9 for 6 X M8	640

* Ød can be machined to customer requirement.

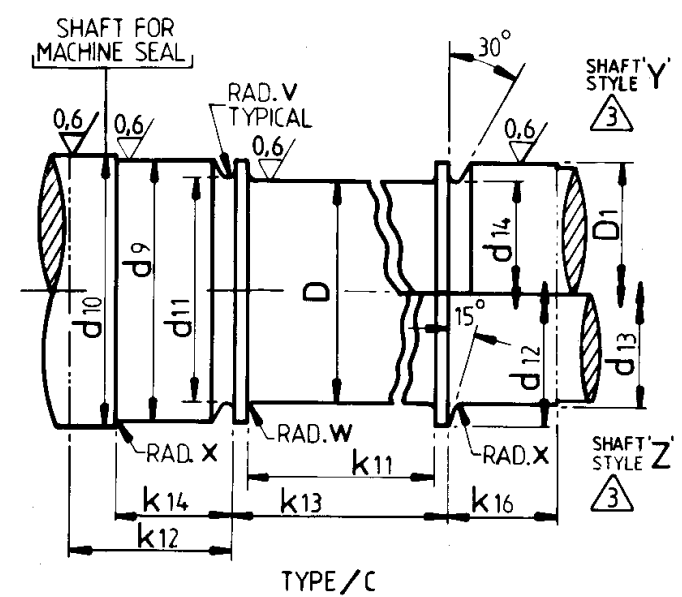
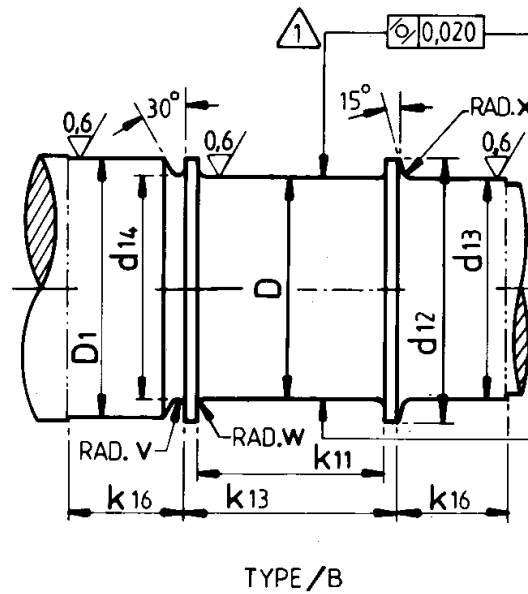
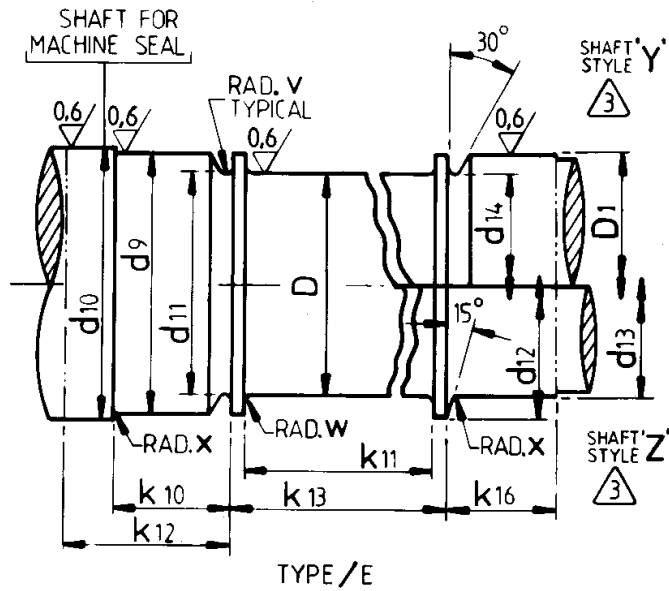

NON LOCATING SHAFTS

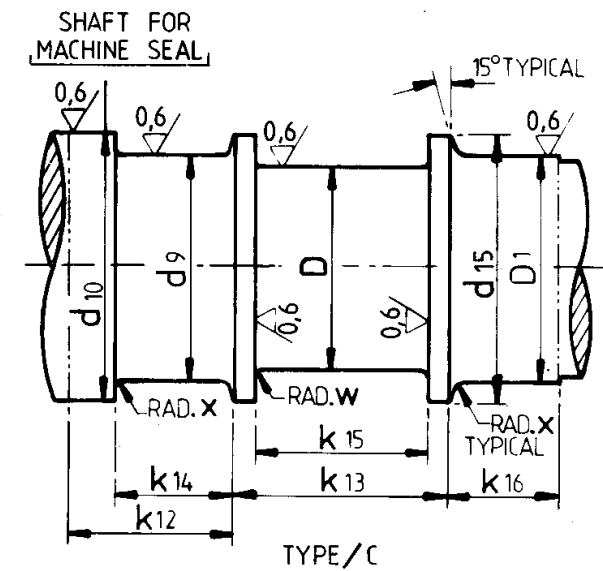
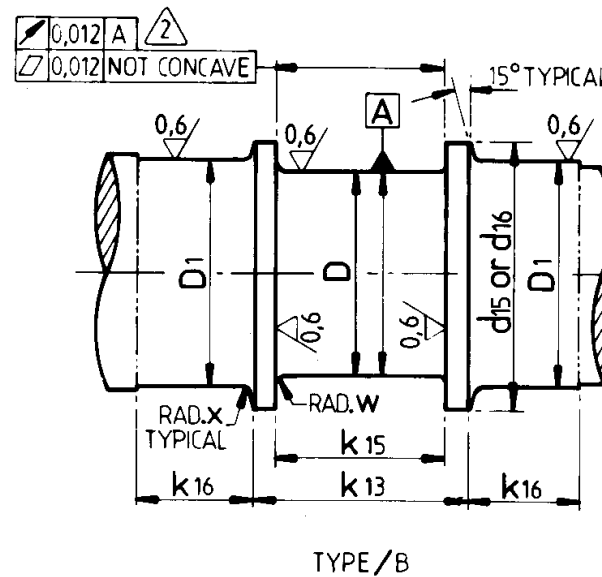
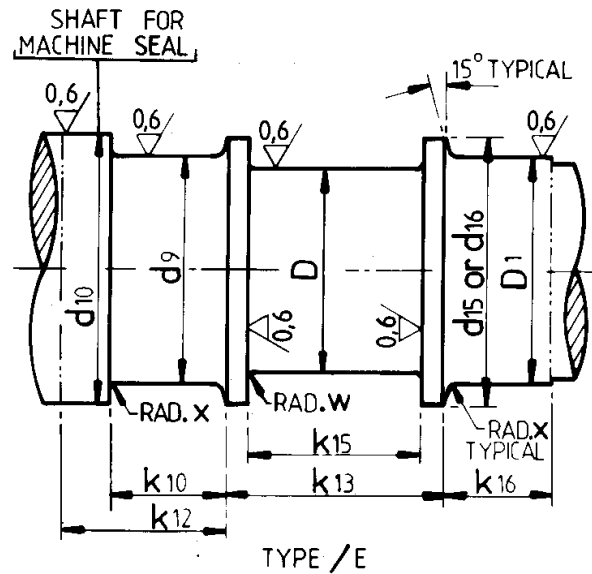

LOCATING SHAFTS

Shaft Dimensions: Table 6 - Shaft dimensions



Frame Size	D	D1 (e8)	d9 (e8)	d10	d11	d12	d13 (e8)	d14(withD1)	d15 @	d16 @	k10	k11	k12	k13	k14	k15 ±0,1	k16		v	w	x	
																	Type SS seal	Type SD seal				
9	80	80	80	120	90	90	80	80 (90)	110	Refer to GB Bearings (Pty) Limited	50	90	100	100	58	80.4	55	75	1.6	2.5	4	
	90	90	90			90 (100)	120	100	90 or less													100 (110)
11	100	100	100	150	110	110	100	100 (110)	135		55	110	105	120	63	100.4	60	80	1.6	2.5	4	
	110	110	110			100 (125)	150	125	110 or less													125 (140)
14	125	125	125	190	140	140	125	125 (140)	170		60	140	115	150	73	125.4	65	85	2.5	4	6	
	140	140	140			140 (160)	190	160	145 or less													160 (180)
	(160)	160	160			160 (180)	(200)	180	160 or less													160 (180)
18	160	160	160	240	180	180	160	160 (180)	215		65	180	125	190	74	160.4	65	90	2.5	4	6	
	180	180	180			180 (200)	240	200	180 or less													180 (200)
	200	200	200			200 (210)	(250)	(225)	200 or less													200 (210)
22	200	200	200	290	225	225	200	200 (225)	265	70	220	140	240	80	200.4	75	105	4	6	10		
	225	225	225			225 (250)	290	250	225 or less												225 (250)	
	(250)	250	250			250 (280)	315	(280)	250 or less												250 (280)	
28	250	250	250	355	280	280	250	250 (280)	325	75	280	155	300	85	250.4	90 /C 80 /E & /B	120 /C 110 /E & /B	6	6	10		
	280	280	280			280 (315)	355	315	280 or less												280 (315)	
	300	315	315		315 (355)	375	300	300 or less	315 (355)													

- Note: ① Geometric tolerance features applicable to all locating and non-locating shafts.
 ② Geometric tolerance features applicable to all locating shafts only.
 ③ Shaft style Y or Z at customer's choice.
 ④ Dimensions in brackets thus (160) are on units to special order.

- Notes: ⑤ d15 collar is for use with plain or taper land thrust bearings.
 d16 collar is for use with GB Bearings tilting pad thrust bearings.
 ⑥ Surface finish in micrometers Ra
 All dimensions in mm.

Bearing Selection



By following the sequence laid down in the succeeding sections, and making technical choices at each stage, someone new to specifying GB Bearings HSR bearings can rapidly make a final selection.

Load Capacity

The initial selection is dependent on the load to be carried. As the bearing is normally limited to a maximum specific load (equivalent to bearing pressure) of 2.5Mpa, this dictates the shaft diameter and the bearing frame size. Figure 1 shows the maximum normal running load in Newtons for bearings in the standard range of HSR frame sizes and shaft diameters.

In certain circumstances it may be possible to increase the maximum allowable specific load, and GB Bearings should be consulted if this is required.

Figure 1 also shows maximum loads at start-up. These are lower than those for normal running because, at low speeds, the rotation of the shaft will not maintain a film of oil adequate for supporting a high load. Where machinery is to be started frequently, and start-up loads exceed these values, an oil jacking system should be specified if excessive wear is to be avoided.

Where specific loads in excess of 2 Mpa are to be carried by bearing assemblies of frame size 22 and 28, careful selection of bearing clearance and oil type may be required to maintain adequate oil film thickness.

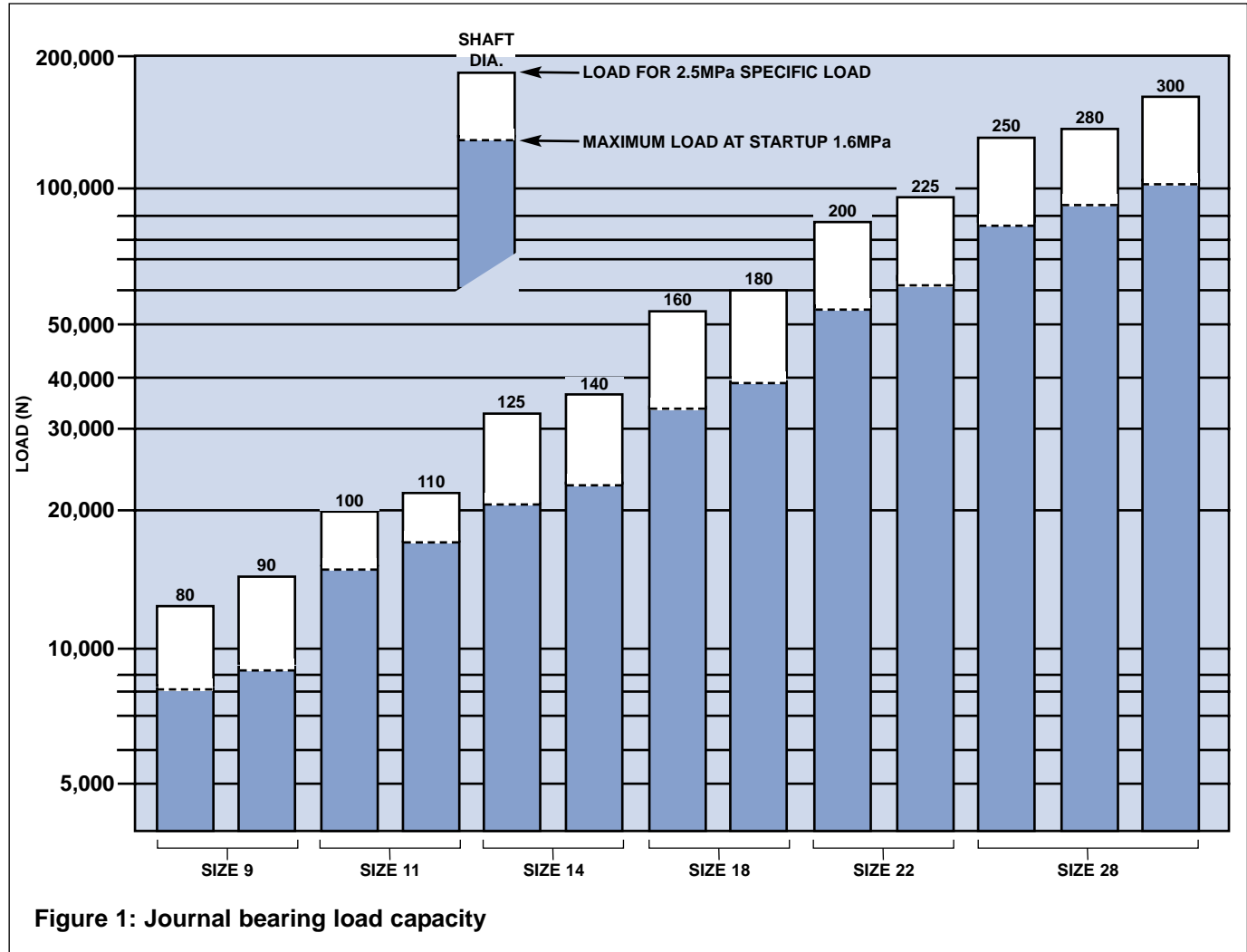

Figure 1: Journal bearing load capacity

Speeds and Clearances

For speeds below 500 rev/min the load carrying capacity of the bearing is limited and GB Bearings should be consulted for information on bearing clearance and oil for such applications.

The maximum allowable surface velocity for ring lubrication is 20m/s. This upper limit has been related to shaft diameter and shaft speed in Figure 2.

Where greater speeds are required, an external oil supply should be specified.

Figure 2 also shows, for each shaft diameter, the minimum diametral clearances for oil ring lubrication over a range of maximum continuous operating speeds. However, this is for guidance only, as the choice of bearing clearance is influenced by many other factors including:

- load
- ambient conditions
- choice of lubricant
- site environment
- method of cooling

Shaft Diameter

The manufacturing diameters of the shaft with the upper and lower limits, may be obtained from the information in Figure 2 and Table 7, and calculated as follows:

Shaft max. dia. = nominal shaft diameter – min. diametral clearance

Shaft min. dia. = shaft max dia – shaft diametral tolerance.

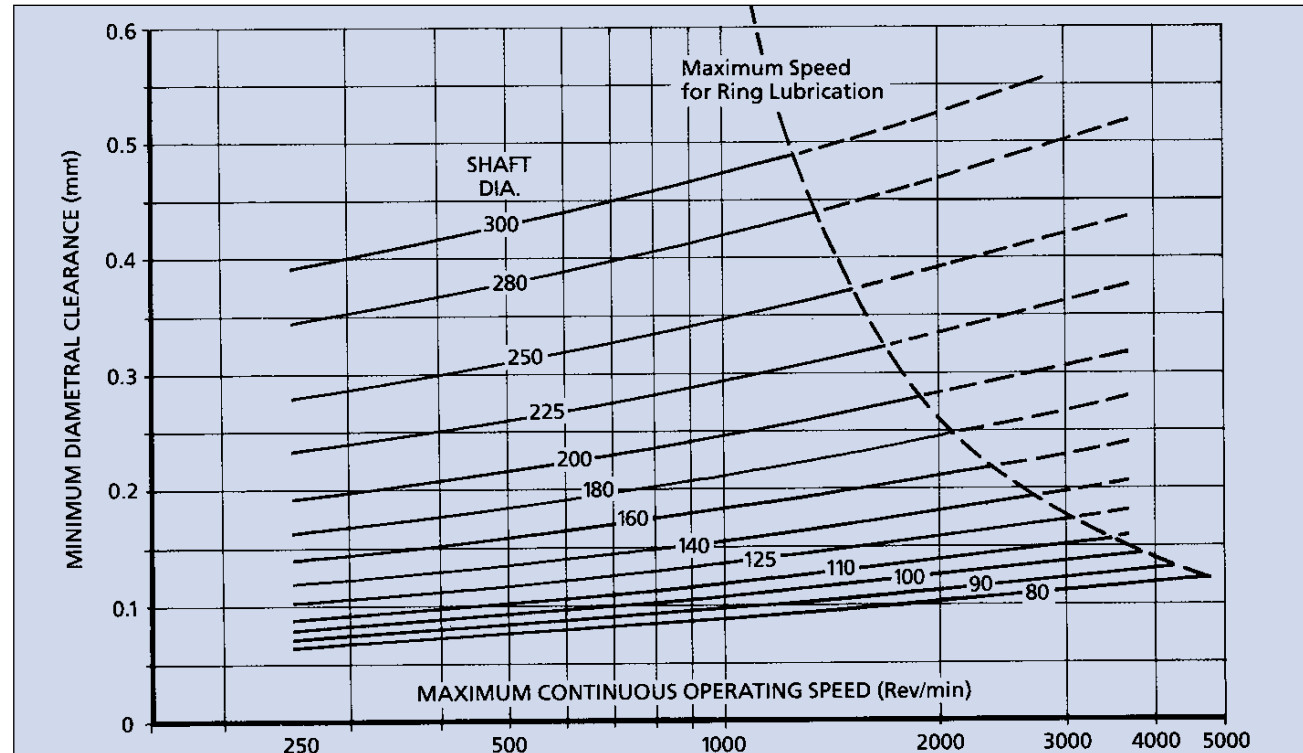

Figure 2: Recommended Diametral Clearance for Oil Ring Lubrication

Example:

For a 100mm shaft operating at 3000 rev/min

$$D \text{ max.} = 100 - 0.140 = 99.860$$

$$D \text{ min.} = 99.860 - 0.022 = 99.838$$

Frame size	Nominal shaft diameter (mm)	Shaft tolerances (0.001mm)	
		Shaft diametral tolerance	
9	80	0.019	
	90	0.022	
11	100	0.022	
	110	0.022	
14	125	0.025	
	140	0.025	
18	160	0.025	
	180	0.025	
22	200	0.029	
	225	0.029	
28	250	0.029	
	280	0.032	
	300	0.032	

Table 7: Manufacturing Tolerances

Bearing Selection



Limits of Natural Cooling

The operating temperature of the journal bearing is limited by the maximum allowable bearing metal temperature and the temperature of the oil in the sump. Figure 3 and 4 show the maximum speeds for the natural cooling related to specific load and shaft diameter for oils ISO VG 32 and ISO VG 46 respectively.

The upper and lower limits of natural cooling, defining the shaded areas on Figures 3 and 4, apply to minimum and maximum bearing clearance respectively. The operating temperature is significantly affected by the bearing clearance and the clearances used for those curves were taken from Figure 2 and Table 7 at the maximum allowable speed for ring lubrication or 3600 rev./min., whichever was the lower speed. For applications where the combination of load, speed and shaft diameter falls below the relevant shaded area in Figures 3 and 4, natural cooling should be satisfactory. For applications where this combination falls above the shaded area, water cooling and/or external oil supply may be required.

Applications falling within the shaded area require careful choice of bearing clearance and should be referred to GB Bearings. A number of other factors may result in different limiting speeds for natural cooling. These are:

A. The type of case. The data in Figure 3 and 4 apply to base mounted assemblies run with no electrical insulation. Other arrangements may have different characteristics.

- B. Combinations of load, speed, ambient temperatures and bearing clearance different to those in Figure 3 and 4.
- C. A steady axial load will require significantly more energy to be dissipated, such applications should always be referred to GB Bearings.

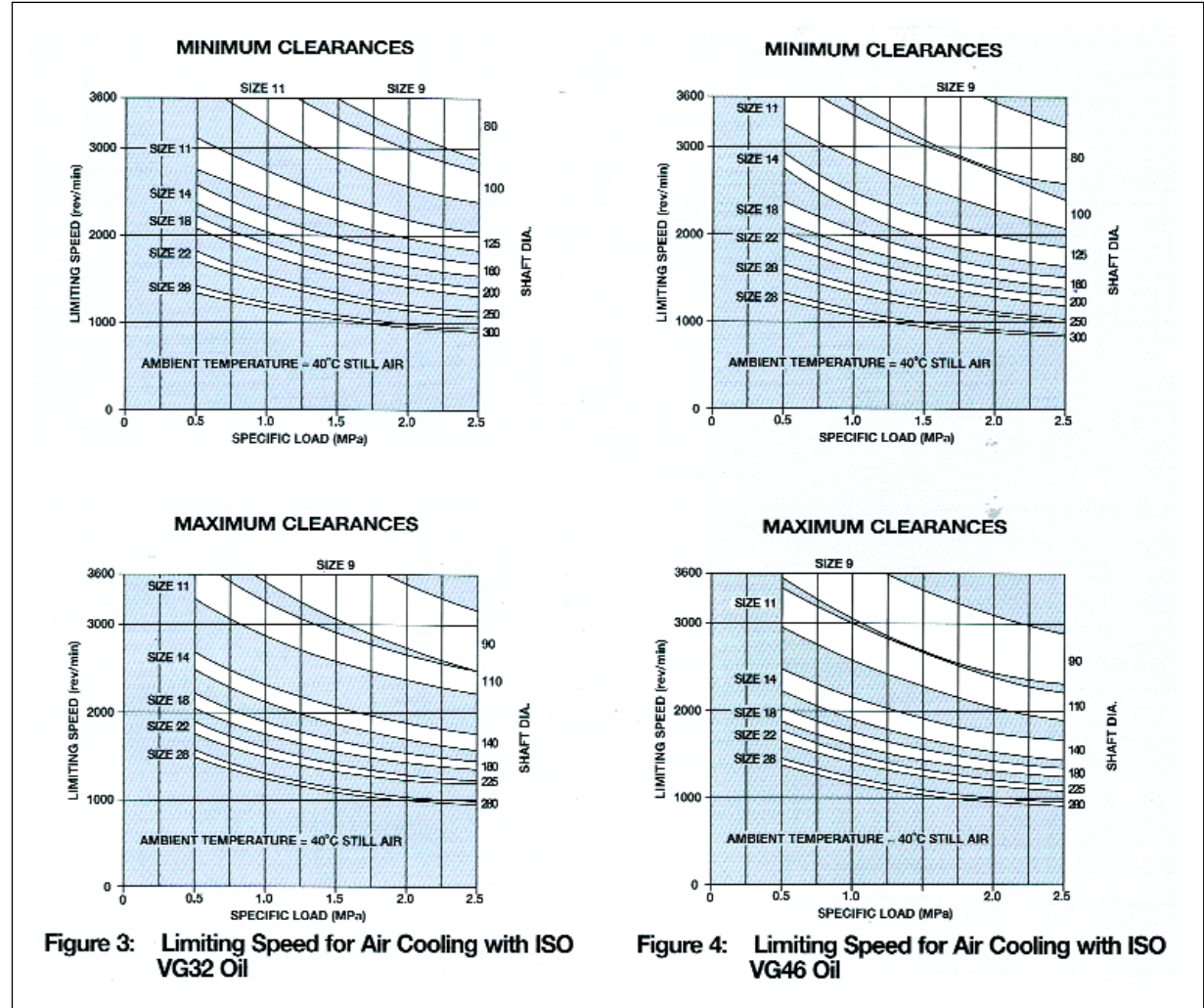

Figure 3: Limiting Speed for Air Cooling with ISO VG32 Oil

Figure 4: Limiting Speed for Air Cooling with ISO VG46 Oil

Bearing Selection



Thrust Loading

Standard HSR bearing assemblies have lined, plain thrust faces and will act as either locating or non-locating bearings. The plain thrust face can carry some axial load (see Table 8) but in cases where a higher thrust capacity is required, the following alternative thrust faces should be specified.

For most applications, taper land thrust faces will be sufficient. Their load capacity is usually limited by the minimum allowable film thickness, and a detailed calculation must be undertaken by GB Bearings to ensure safe operation.

However, **Table 8 gives some guidance only** on their specified axial load capacity.

For greater axial loads, tilting pad thrust bearings should be used. All HSR assemblies can be fitted with thrust pads from the standard range of GB Bearings Tilting Pad Thrust bearings. Details available on request.

Confirmation of Selection

Even where the selection of a bearing appears to fall within all the design criteria, GB Bearings recommends that customers confirm their selection by completing the ordering details given in page 17 of this handbook. GB Bearings bearing design computer program will then be used to predict the operating conditions of the bearing, and the customer will be supplied with this data including stiffness and damping coefficients for the journal bearing.

Frame size	Shaft diameter (mm)	Plain thrust load (N)	Taper thrust load (N)
9	80	1 100	2 500
	90	1 200	3 000
11	100	1 550	3 800
	110	2 000	5 000
14	125	2 550	6 250
	140	3 200	8 000
18	160	3 900	10 000
	180	4 900	12 000
22	200	5 750	14 500
	225	6 350	16 500
28	250	8 250	20 500
	280	9 050	23 000
	300	9 600	25 000

Table 8: Maximum thrust (axial) loads at optimum speeds

Special Designs

Manufactured to Customer Requirements

GB Bearings offers a range of assembly bearings and a service which is among the most comprehensive and versatile world-wide.

GB Bearings is able to meet virtually any specification. Our standard designs can be readily adapted or we can manufacture bearings to customer designs.

Our customers enjoy the benefits of close liaison and expertise at every stage and the quality of our technical assistance is well known.

Optional features



Water Cooling

Where bearing selection tables indicate that power losses exceed the heat dissipation characteristics of air cooled units, water cooling tubes can be fitted in the oil sump. GB Bearings will advise on their specification and the connections required on receipt of information on the expected operating conditions.

External Pressure Lubrication

Pressure lubrication is likely to be specified for applications with high or low speeds, where water-cooling is insufficient, or where tilting pad thrust bearings are used. The external circulation/cooling system will need to be designed for each application, according to the calculated power losses. GB Bearings will be pleased to advise.

Oil inlet and outlet sizes are shown in the size tables. Where oil is fed to the bearing from an external source, the oil level in the sump is controlled by a weir plate in the oil outlet. The oil pick-up ring may be retained to ensure that oil still reaches the bearing in the event of a failure in the external supply, or during run-down.

For all cases, GB Bearings will advise on oil flows and pressures.

Hydrostatic Jacking

Where the specific load (bearing pressure) on start-up exceeds values indicated on Page 10, a hydrostatic jacking system should be incorporated. GB Bearings will recommend the necessary oil supply pressure and flow rate required on receipt of information on the expected start-up conditions.

Profile Bore Journal Bearings

Profiled bores provide improved shaft damping and greater oil film stability than the standard cylindrical bearing in higher speed applications. For these situations, HSR bearings fitted with lemon bore, offset halves, or 3 and 4 lobe bore profiles can be supplied.

Tilting Pad Journal Bearings

For higher speed machines, and where vibration levels need to be reduced, tilting pad journal bearings offer the most stable running conditions under a wide range of loads and speeds. As they can accept loads from any radial direction, tilting pad journal bearings offer special advantages for electric motors where the influence of magnetic fields may not be precisely known.

All HSR assemblies can be fitted with tilting pad journal bearings, using journal pads from GB Bearings (in HSR assemblies, the length/diameter ratio of these bearings will normally be 0.7). Details available on request.

Instrumentation

Whatever instrumentation may be needed by a customer, it should be discussed with GB Bearings as early as possible. Many of these are proprietary items, so where a customer has a particular preference, he should state it. Typical specification requirements are given as follows:

Temperature sensors

Type of sensor: thermocouple
resistance temperature detector (RTD)
others

Materials: copper/constantan pair for thermocouple or platinum
100 ohm resistance at 0°C for RTD

Cable material: e.g. Teflon covered,
stainless steel sheath, etc.

Cable length: 3m

Proximity Probes

Type of Sensor: e.g. inductive probe

Cable material: e.g. Teflon covered,
stainless steel sheath, etc.

Number and position of probes in unit: e.g. two probes at 90 degrees on the outboard seal housing

Insulation

Where the shaft needs to be insulated electrically from the bearing mounting, HSR assemblies can be fitted with insulating material between the bearing and the casing.

Materials

The casing and bearing housing can be made from special materials when this is required. However, price and delivery may be affected.

A Valuable Analysis Service

Excessive rotor vibration can damage machinery, and shorten its life. Therefore, GB Bearings operates a rotor dynamics analysis service so that a machine's rotor dynamics can be evaluated at the design stage.

The includes detailed interactive computer studies of complete shaft systems to avoid costly rotor dynamics problems.

Techniques employed to investigate the dynamic interaction between journal bearings and rotor include:

- undamped natural frequency analysis
- damped natural frequency (stability) analysis
- synchronous response to unbalanced analysis

Computer studies of entire shaft systems are carried out at agreed fees. Alternatively, GB Bearings will supply bearing operating data and dynamic coefficients as part of its normal service to enable customers to conduct their own analysis.

Exchange Service

GB Bearings also provides a bearing repair service with many standard sizes available ex-stock on a service exchange basis.

In addition, standard spares, such as standard floating labyrinth seals and oil pick-up rings are readily available.

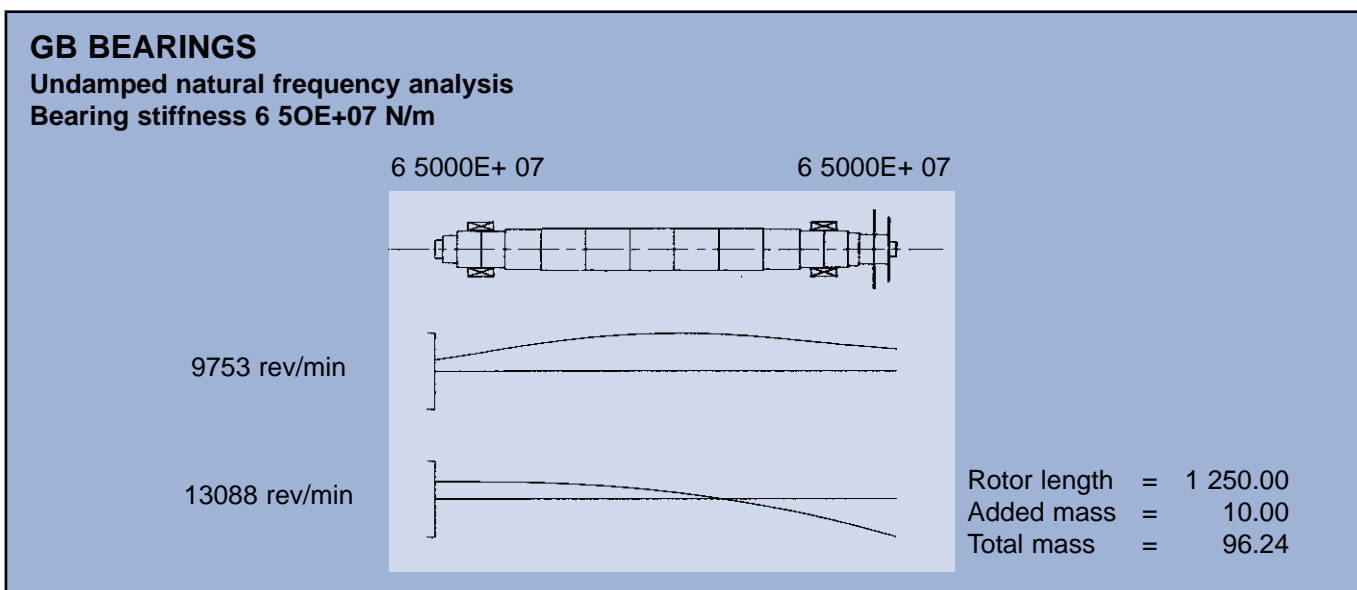

Assembly order codes

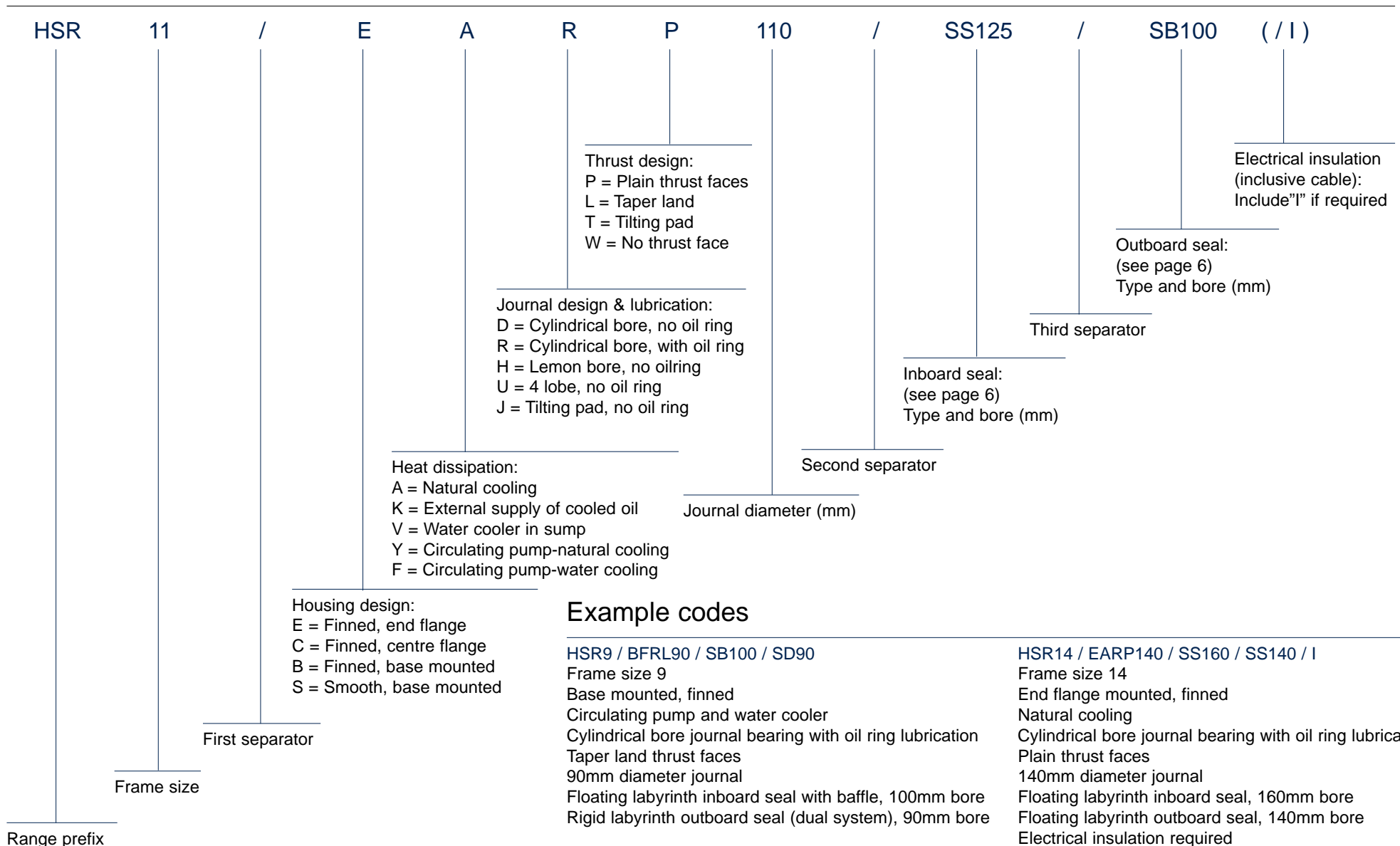

Ordering Details



Please complete this page, photocopy and return to GB Bearings by post or fax. Alternatively, you can complete and submit a form from our website.

Durban Office
PO Box 2121
Pinetown, 3600
South Africa

Johannesburg Office
PO Box 8066
Elandsfontein, 1406
South Africa

Tel: +27 (0) 31 792 5900 Tel: +27 (0) 11 974 1291
Fax: +27 (0) 31 700 3613 Fax: +27 (0) 11 974 1468
www.gbbearings.co.za

HSR enquiry data sheet

Customer: _____

Contact Person: _____

Telephone No: _____

Fax No: _____

Mobile No: _____

Email address: _____

Customer Reference No: _____

Site Location: _____

Application: _____

Motor Alt/Gen Other

State: _____

Number of assemblies required: _____

Delivery required: _____

The following information is required:

1. Reference code of HSR selected from Page 16 of this handbook is:

HSR _____

2. Shaft speed

Normal: _____ rev/min

Overspeed: _____ rev/min

Maximum: _____ rev/min

3. Radial load

Normal: _____ N

Maximum: _____ N

Start-up: _____ N

Load direction:

Steady Rotating

Vertically downwards:

Yes No

4. Axial (Thrust) Load (Main direction)

Normal: _____ N

Maximum: _____ N

Start-up: _____ N

Axial (Thrust) Load (Reverse direction)

Normal: _____ N

Maximum: _____ N

Start-up: _____ N

5. Oil grade to be used: _____

6. Shaft diameter: _____ mm

(with tolerance if not IT6)

7. Ambient air temperature

Normal: _____ °C Max: _____ °C

8. External air velocity

Normal: _____ m/s Max: _____ m/s

Additional information required to describe optional features (page 14)

Durban

Pinemead Industrial Park
47 Gillitts Road, Pinetown
Kwazulu Natal
South Africa

PO Box 2121
Pinetown, 3600
South Africa

Tel: +27 (0) 31 792 5900
Fax: +27 (0) 31 700 3613

Cape Town

Unit 2, Wessex Street
Paarden Eiland
Western Cape
South Africa

PO Box 6192
Roggebaai, 8012
South Africa

Tel: +27 (0) 21 511 1636
Fax: +27 (0) 21 511 0183

Johannesburg

1 Essex Street
Elandsfontein
Gauteng
South Africa

PO Box 8066
Elandsfontein, 1406
South Africa

Tel: +27 (0) 11 974 1291
Fax: +27 (0) 11 974 1468

GLACIER

DEVA

LICENSEE TO
WB WAUKESHA
BEARINGS

GLYCO

**FEDERAL
MOGUL**



TENMAT



GB Bearings (Pty) Ltd
www.gbbearings.co.za